

Brake Vacuum Kit

Items included in this kit:

Part Name	Quantity
Junction Block	1
$\frac{1}{4}$ BSPP 10mm Barb Fitting	3
10mm 1-Way Valve	1
$\frac{1}{4}$ BSPP Vacuum Pressure Sensor	1
Reservoir	1
Vacuum Pump	1
10mm Vacuum Hose	~2 metre length
5mm Rubber Hose	~5cm length
12V 15A Relay	1
Relay Holder	1
Pins	5

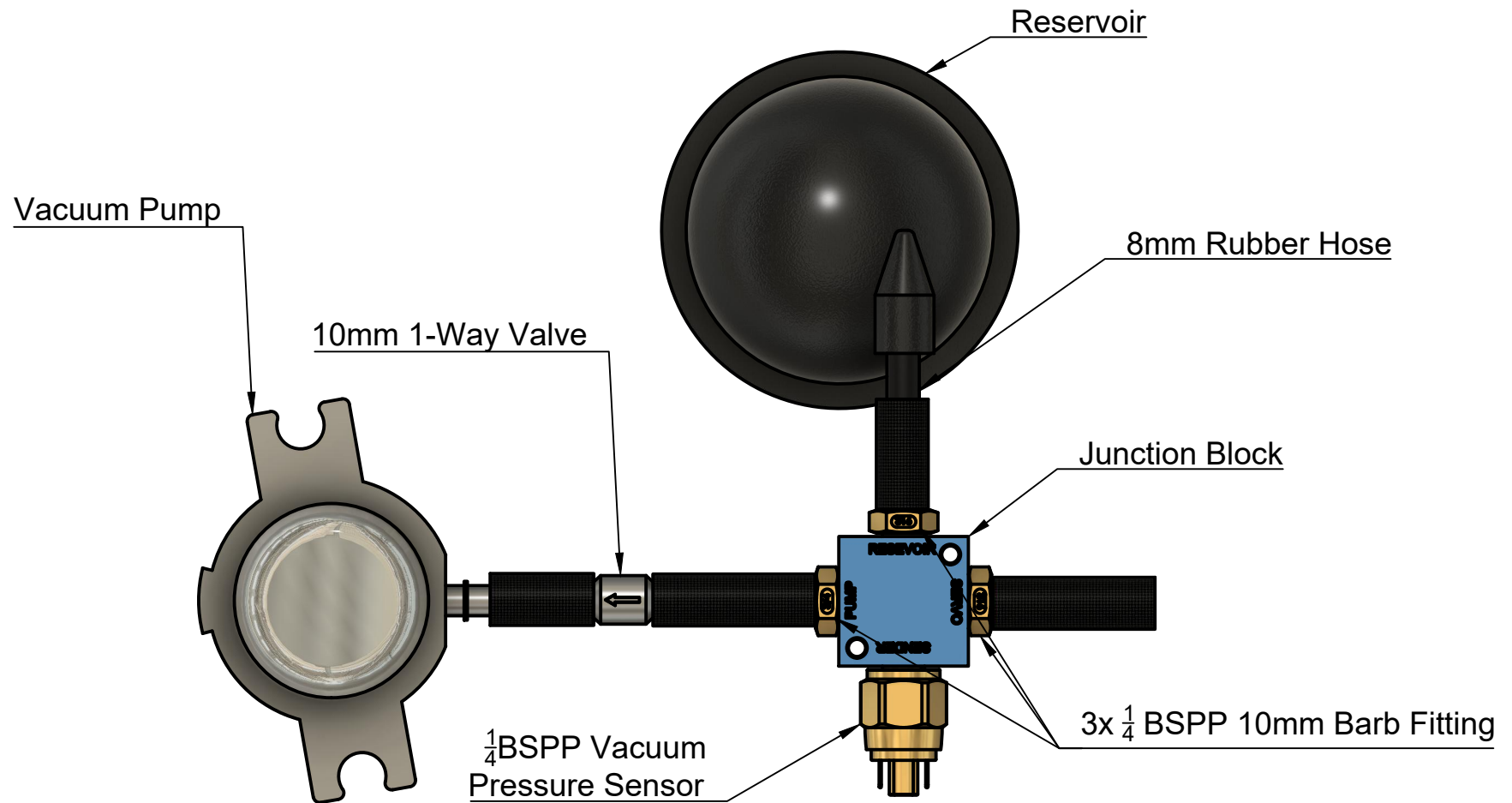



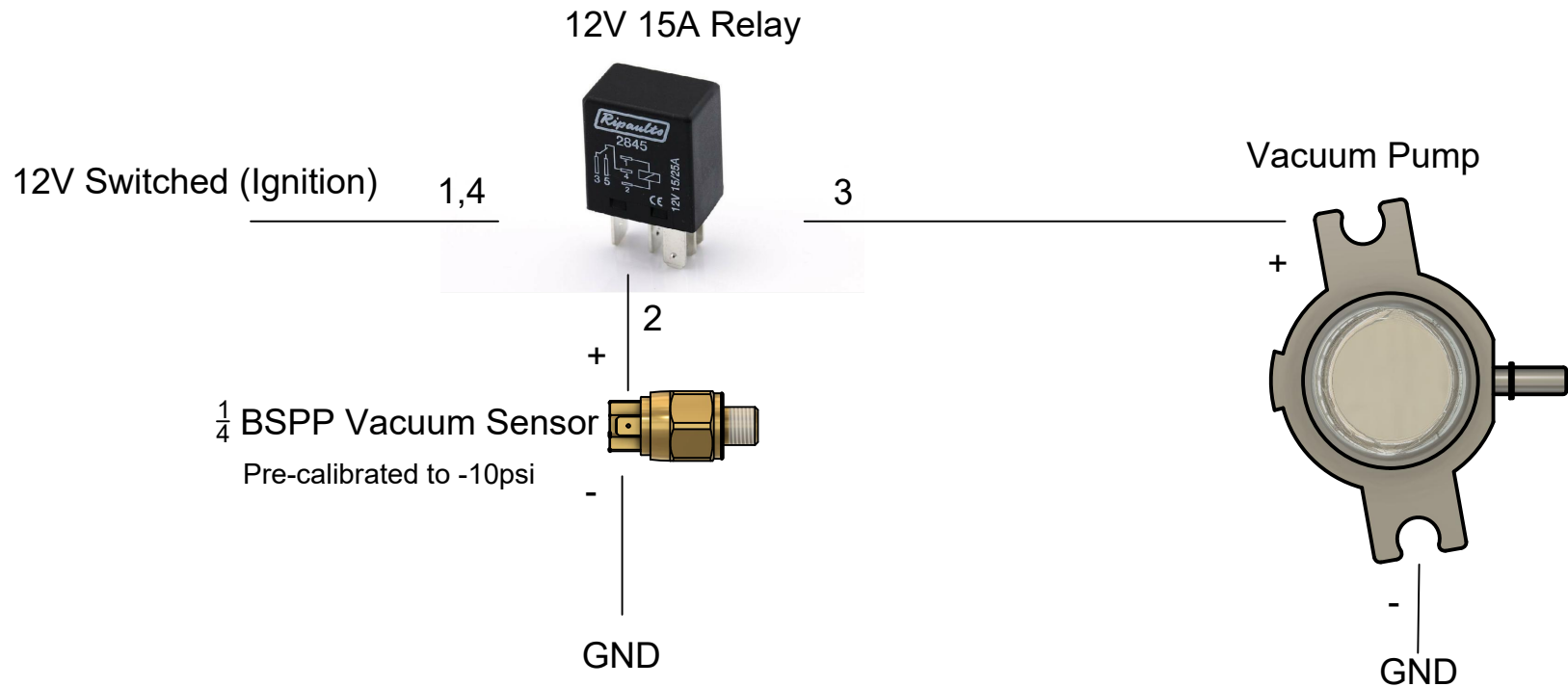

Dept.	Technical reference	Material:	Created By: Annie Hazell 14/06/2024	
Scale Not to Scale		Colour: N/A	Approved By:	
Notes: <ul style="list-style-type: none"> • All units in mm • Unspecified tolerances are $\pm 0.1\text{mm}$ • Remove all sharp edges and burrs 		Finish:	Title: Brake Vacuum Kit	
			Project: Fellten	
			Rev.	Date of issue

Wiring Diagram

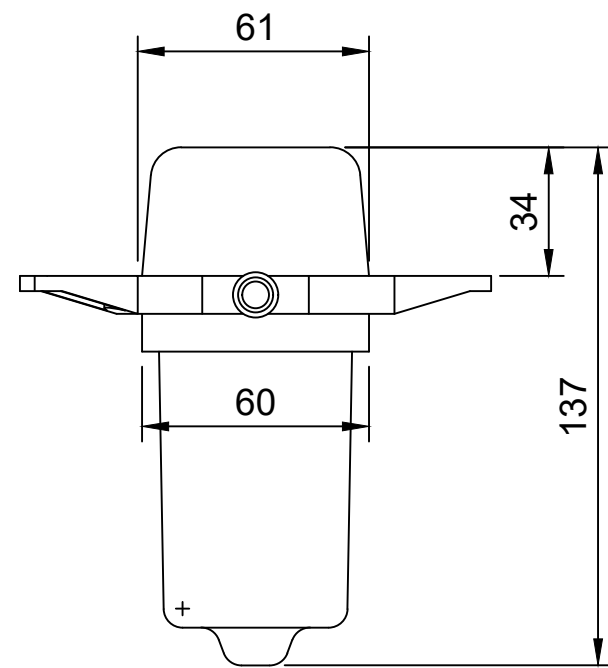
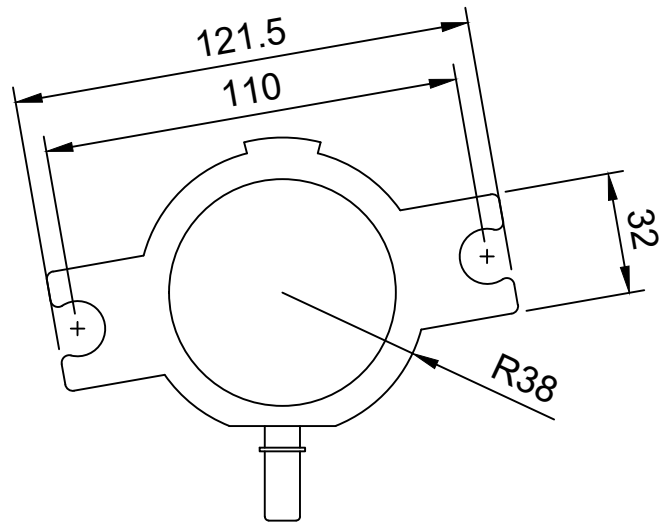

Dept.	Technical reference	Material:	Created By: Annie Hazell 14/06/2024	
Scale Not To Scale		Colour: N/A	Approved By:	
Notes: <ul style="list-style-type: none"> All units in mm Unspecified tolerances are $\pm 0.1\text{mm}$ Remove all sharp edges and burrs 		Finish:	Title: Brake Vacuum Kit	
			Project: Fellten	
			Rev.	Date of issue



Dept.	Technical reference	Material:	Created By: Annie Hazell 14/06/2024	
Scale 1:2		Colour: N/A	Approved By:	
Notes: <ul style="list-style-type: none"> All units in mm Unspecified tolerances are $\pm 0.1\text{mm}$ Remove all sharp edges and burrs 		Finish:	Title: Brake Vacuum Kit - Pump	
			Project: Fellten	
			Rev.	Date of issue

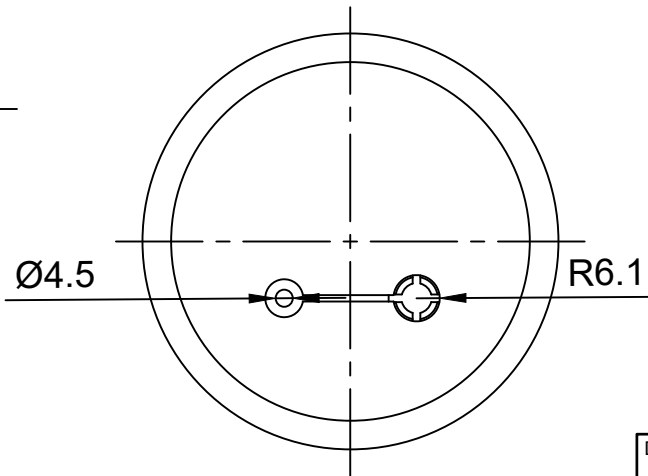
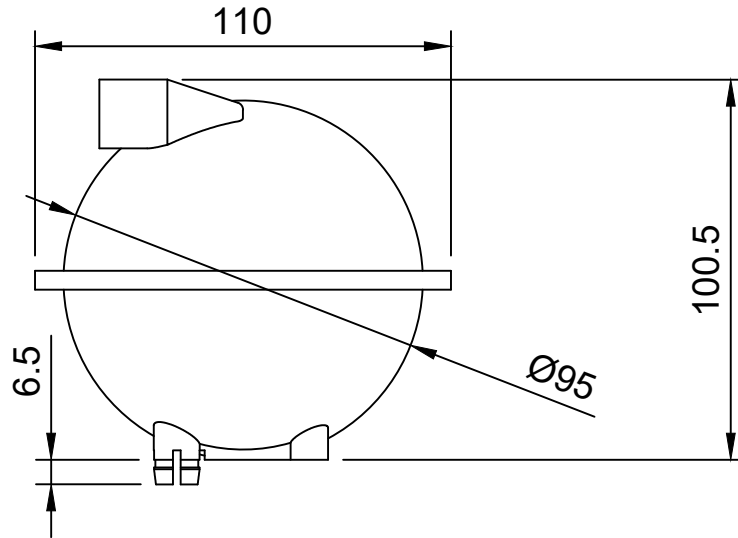

Dept.	Technical reference	Material:	Created By: Annie Hazell 14/06/2024	
Scale 1:2		Colour: N/A	Approved By:	
Notes: <ul style="list-style-type: none"> All units in mm Unspecified tolerances are $\pm 0.1\text{mm}$ Remove all sharp edges and burrs 		Finish:	Title: Brake Vacuum Kit - Reservoir	
			Project: Felten	
			Rev.	Date of issue