

USER MANUAL



HK-J Series 6.6KW UHF CAN Bus Battery Charger

1. Overview

The HK-J series 6.6KW UHF charger was specially designed for charging electric vehicle batteries based on national standards. This product has the advantage of not only high efficiency, small size, high stability and long lifespan, but also high protection grade, high reliability and complete protection. It is definitely an ideal charging solution for electric vehicles.

This charger has a internal heat sensor and can automatically recover from thermal protection. Fully sealed potting process and IP67 protection level ensures no problems in any harsh environment.

Main Features: Fully sealed, fan cooled (water cooling option available)

Reliably works from -35°C to +85°C internal temperature

Internal temperature sensor

Shuts off when internal temperature is over 90°C

IP67 protection level

Works well in short time immersion

2. Main Parameters

Hardware	DC output Voltage Range	Max Output Current	Lead Acid Battery Charger Model	Lithium Battery Charger Model
48V80A	18-68VDC	80A	HK-J-48-80	HK-J-H66-80
72V80A	25-99VDC	80A	HK-J-72-80	HK-J-H99-80
96V64A	34-132VDC	64A	HK-J-96-64	HK-J-H132-64
144V46A	50-198VDC	46A	HK-J-144-46	HK-J-H198-46
312V20A	110-440VDC	20A	HK-J-312-20	HK-J-H440-20
540V12A	170-650VDC	12A	HK-J-540-12	HK-J-H650-12

3. Features

Items		Data
Input	AC Input Range	AC 90~265V
	Frequency	45-65Hz
	Input Current	≤32A
	Power Factor	≥0.99 Half loading
	Efficiency	≥93% Full loading
	Standby Consumption	≤10W
Main Output	Output Mode	CV / CC
	Output Voltage	6600W @ 220VAC; 3300W @ 120VAC
	CV Accuracy	±1%
	CC Accuracy	±2%

	Ripple Voltage Coefficient	5%
Low Voltage Output	Output Mode	CV
	Output Voltage	13.8V/27.6V
	CV Accuracy	±1%
	Nominal Current	5A
	Max Current	5.5A±0.5A
	CC Accuracy	±2%
	Ripple Voltage Coefficient	1%
	CAN Communication	CAN Communication
Baud Rate		125Kbps、250Kbps、500Kbps
Terminal Resistance		NO

4. Protection

Protection	Input Over-voltage Protection	AC285±5V
	Input Under-voltage Protection	AC85±5V
	Output Over-voltage Protection	Stop the output when exceeds + 1% of the maximum output voltage
	Output Under-voltage Protection	Stop the output when below -5% of the minimum output voltage
	Output Over-current Protection	Stop the output when exceeds + 1% of the maximum output current
	Over-temperature Protection	Power down from 85 °C and shut off at 90 °C
	Short-circuit Protection	Stop Output
	Battery Reverse Connect Protection	Fuse Burned-out
	Ground Protection	≤100mΩ
	CAN communication Protection	Automatically stop the output when CAN communication fails
	Power-off Protection	YES

5. Safety

Safety&Others	Withstand Voltage	Input to Output: 2000VAC≤20mA Input to Ground: 2000VAC≤24mA Output to Ground: 2000VAC≤20mA, all 1min
	Insulation Resistance	Input, output, signal terminal to casing≥10MΩ Testing Voltage 1000VDC
	Electromagnetic Immunity	GB/T 18487.3-2001 11.3.1
	Electromagnetic Abusive	GB/T 18487.3-2001 11.3.2
	Harmonic Current	GB 17625.1-2003 6.7.1.1
	Inrush Starting Current	≤24A
	Current-rise Time	≤5S, Overshoot≤5%
	Close Response time	100% to10%≤50mS, 100% to 0%≤200mS
	Anti-Vibration	10—25Hz Amplitude1.2mm, 25—500Hz 30m/s ² , 8hrs per direction
	Noise	≤60dB(A Class)
	MTBF	150000H

Work Environment	Relative Temp 5%-95% No condensation
Working Temperature	-35□ ~ +85□
Storage Temperature	-55□ ~ +100□

6. Installation Dimensions and Connector Definition

6.1.1 Installation Dimensions (Fan Cooling) Nominal Voltage 144V and below:

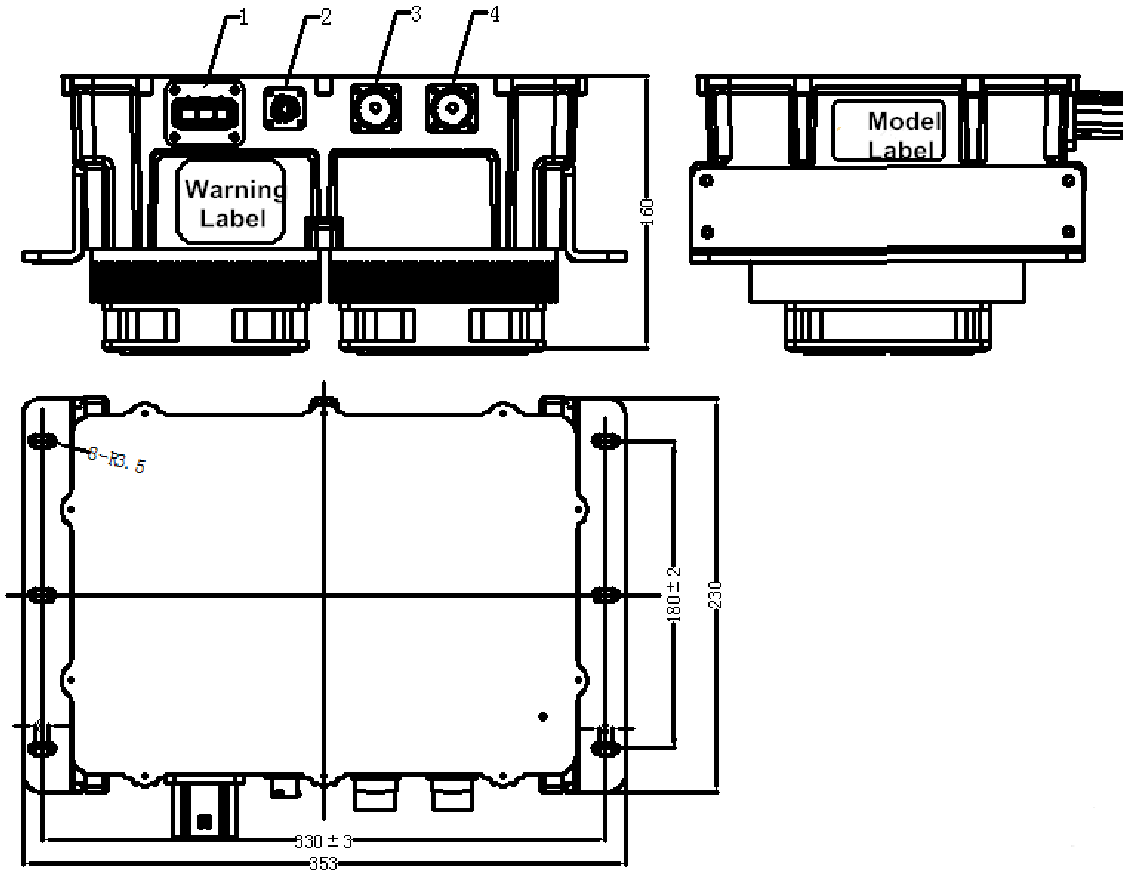

6.1.2 Installation Dimensions (Liquid Cooling)

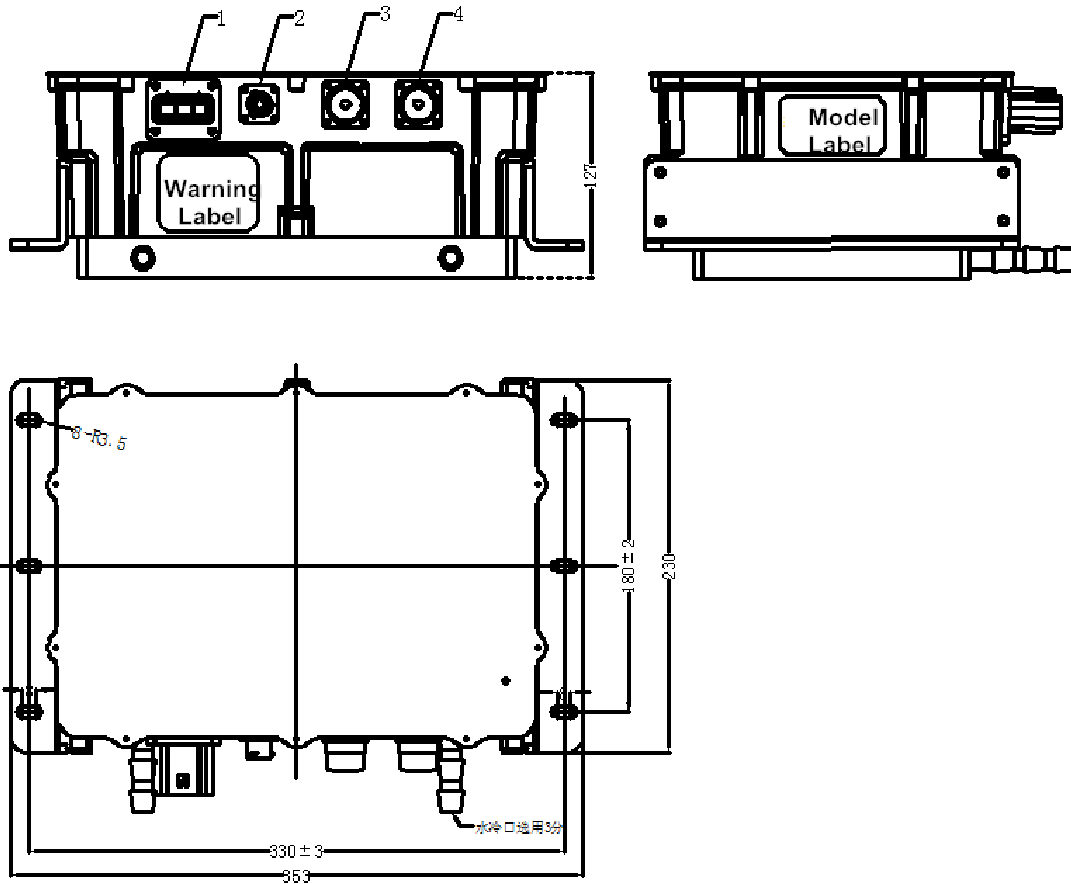

6.2 Interface Definition

S. N.	Terminal Name	Terminal Definition	Male Connector	Female Connector	Ver.
1	Charger's AC Input	A: NULL Line B: GND Line C: Fire Line	XXC106-EV-P3Z	XXC106-EV-S3T	XINXI
2	Signal Control	A-CAN L, B-CAN H, C-CAN GND, D-12V+, E-12V-, F-Enable.	XXC103-EV-P6ZC	XXC103-EV-S6TC	XINXI
3	Charger's DC Output	Positive	DY6-1ZP(180°)	DY6-1TY(180°)	XINXI
4	Charger's DC Output	Negative	DY6-1ZP(90°)	DY6-1TY(90°)	XINXI

6.3 Installation Dimensions (Fan Cooled) Nominal Voltage above 312V, 540v:

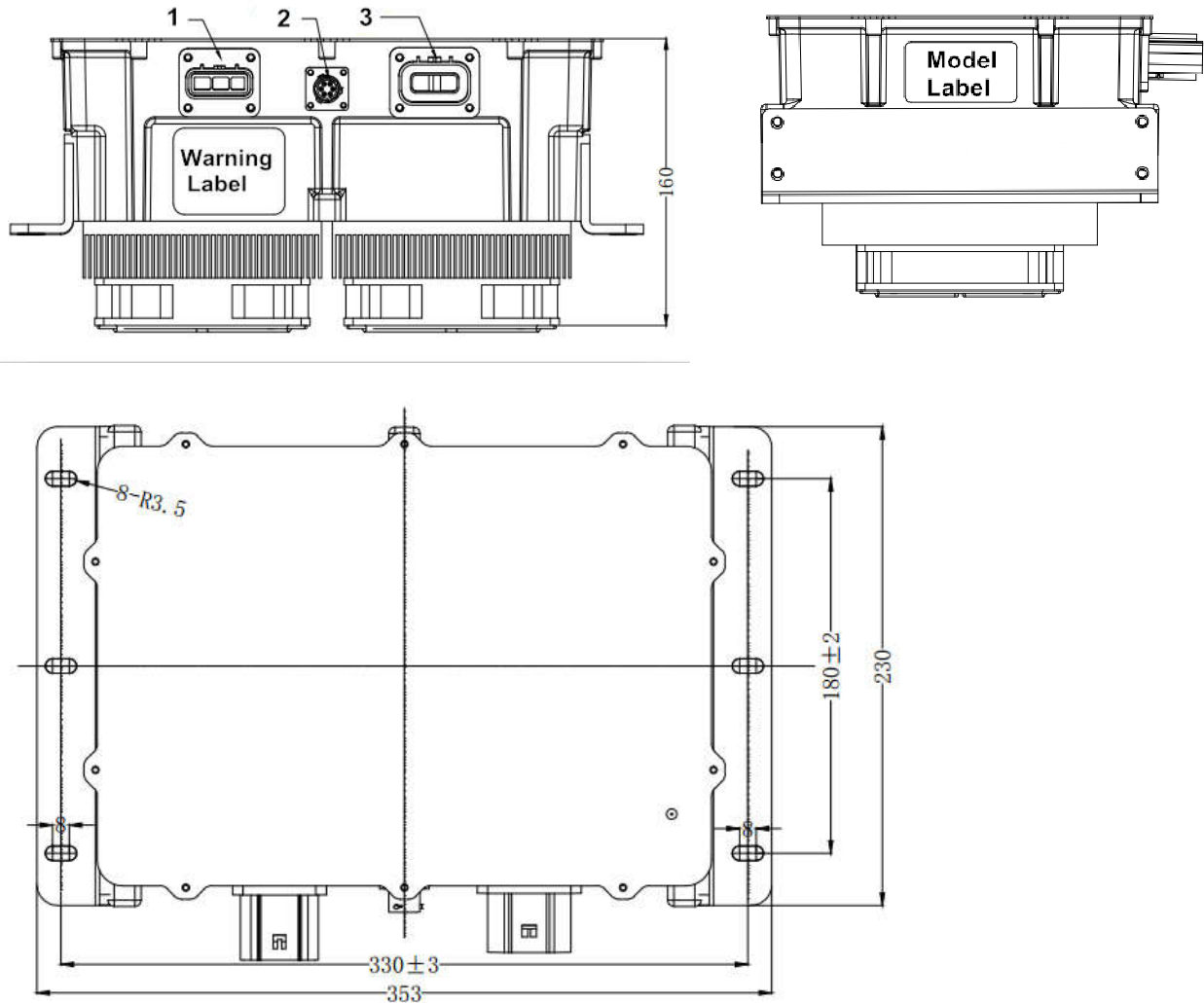

6.4 Interface Definition

S. N.	Terminal Name	Terminal Definition	Male Connector	Female Connector	Ver.
1	Charger's AC Input	A-Null line, B- GND C-Fire Line,	XXC106-EV-P3Z	XXC106-EV-S3T	XINXI
2	Signal Control	A-CANL, B-CANH, C-CANGND, D-12V+, E-12V-, F-Enable	XXC103-EV-P6ZC	XXC103-EV-S6TC	XINXI
3	Charger's DC Output	A-Positive B-Negative	XXC105-EV-P2ZB	XXC105-EV-S2TB	XINXI

6.5 Enable Control

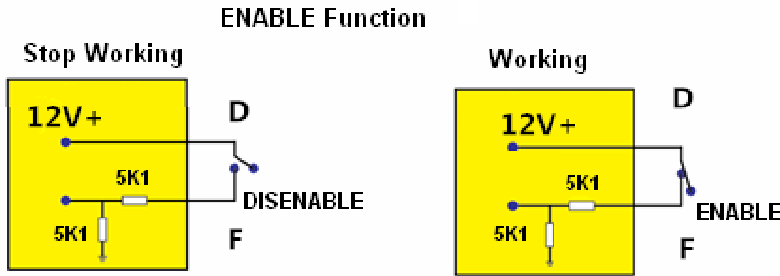

7. LED Colors

1). Initial State

Red Off Green Off Red Off Green Off Red Off Green Off Red Off Green Off

2). Charging State

Red Off Red Off Red Off Red Off Red Off Red Off Red Off Red Off Red Off

3). Stand-by State

Green Off Green Off Green Off Green Off Green Off Green Off Green Off Green Off

4). Fault State

Red Green Red Green.....Other error status word error

Red Green.....Wrong Battery

Red Green Red.....Wrong Communication

Green Red.....Wrong Input Voltage

Green Red Green.....Internal Temperature Protection

Green Red Green Red.....Wrong Hardware

8. Schematic diagram and the efficiency curve

8.1 Schematic Diagram

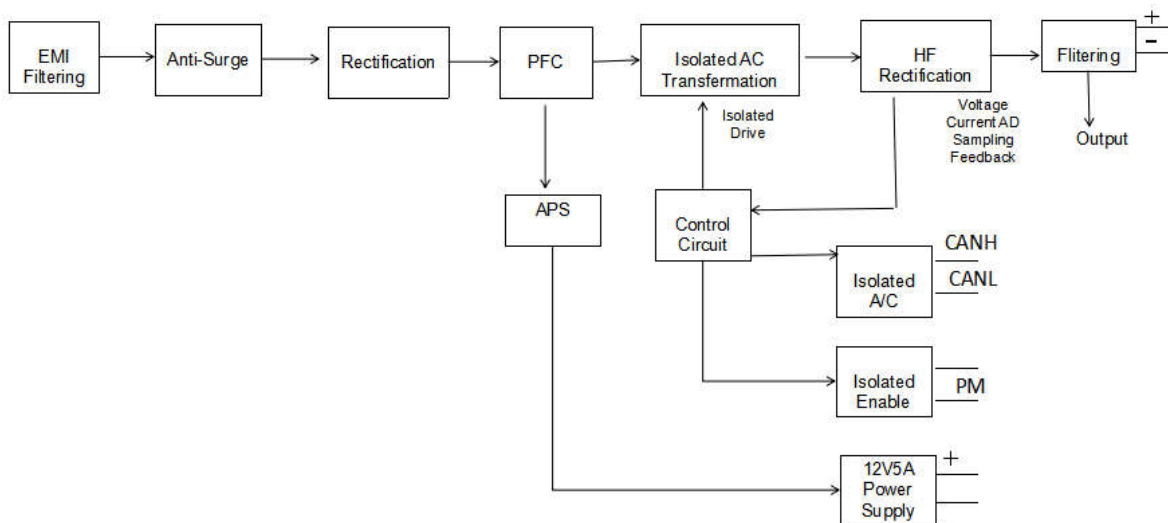

8.2 Efficiency Curve

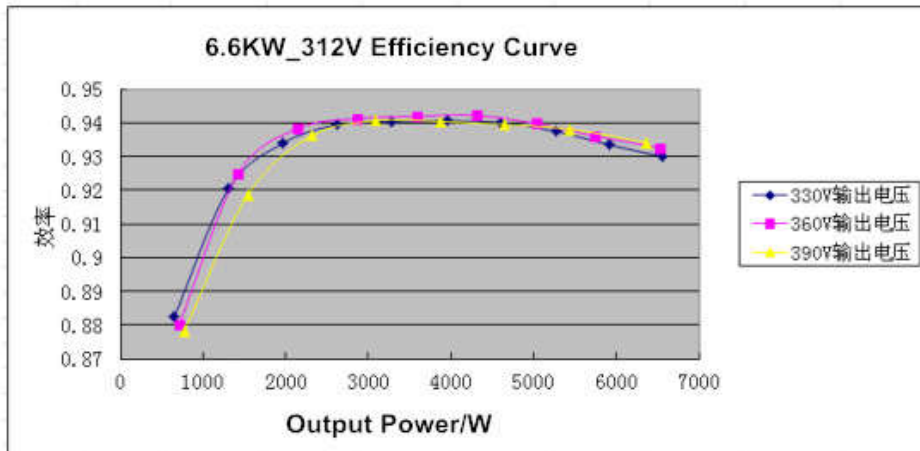

9. Appearance

- 1). Outer surface should be smooth without obvious defects such as scratch, deformation. Surface coating should be uniform.
- 2). The nameplates and signs should be installed firmly with the neat handwriting.
- 3). Spare parts should be fastened reliably without rust, burrs, cracks and other defects and damage.
- 4). Each product should be marked with product identification in obvious place, including part number, product brand, product type, production number, name of production enterprises, the warning message, etc

10. Packaging, Transportation and Storage

1). Packaging

On the packing box, there are product name, product part number, product brand, product type, production number and name of manufacturer; In packing box, along with the technical documents, it includes packing list, quality certificate, product specification.

2). Transportation

Suitable for cars, boats, aircraft, transportation. The products have to be prevented against sunshine and moisture and in a civilized transportation.

3). Storage

Product should be stored in the packing box when it is not used and be maintained in a 5°C to 40°C clean, dry and well-ventilated environment. It should not be stored together with chemicals, acid and alkali substances etc.,. Should avoid storing in the sun, fire, water and avoid storing with corrosive substances. The storage period is 2 years (from the inventory date of the factory). After the 2 years of storage period, the products should still comply with the provisions of the relevant standards.