

User Manual

1KW DC/DC Converter TDC-IY Series

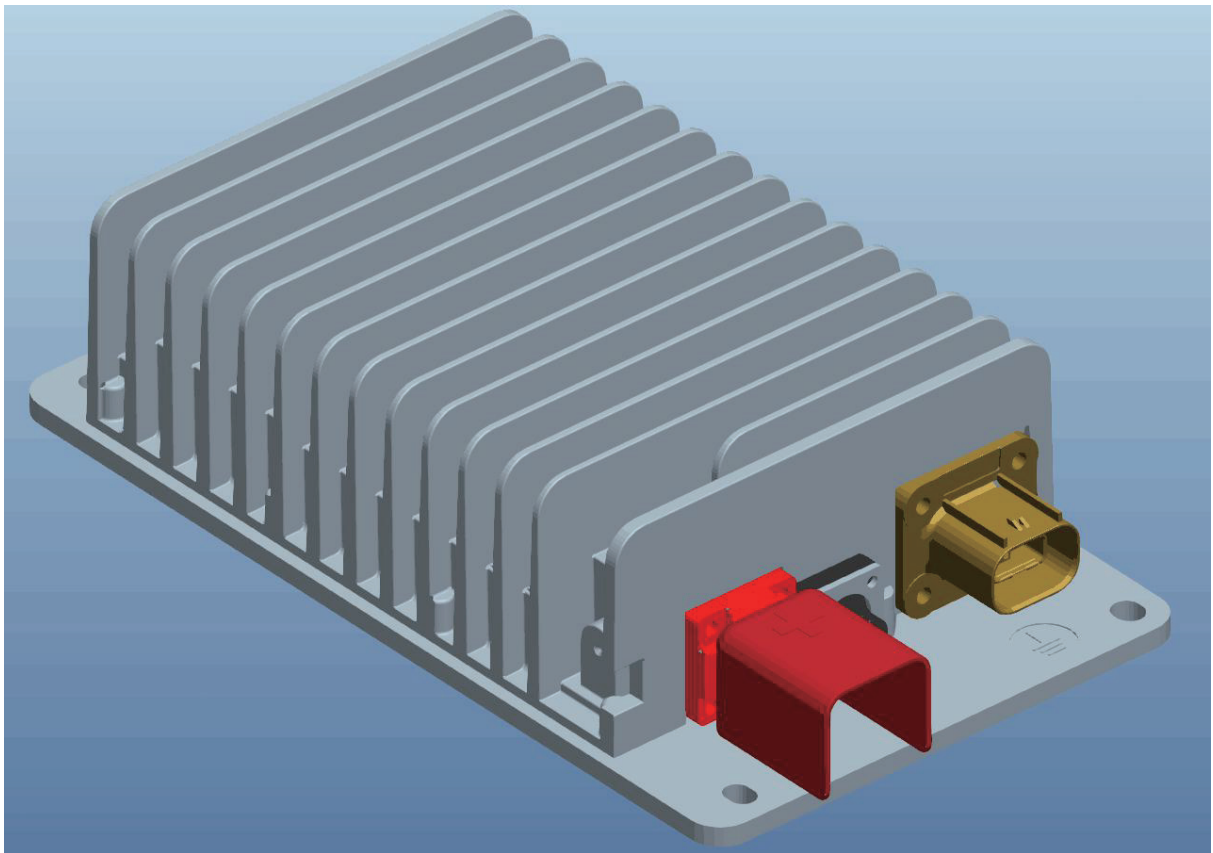

User Manual for 1000W DC/DC Converter

1. Overview

1000W DC-DC Converter, Hangzhou Tie Cheng, can install in electric vehicle, supplying 12V power to low voltage application in vehicle. Output terminal can connect directly to 12V back-up battery pack. DC-DC Converter will management the charging process of back-up battery automatically. Fully sealed potting can be highly waterproof and dust proof, highly temperature resistance, highly vibration resistance.

The diagram between DC-DC Converter, 12v back-up battery pack, low voltage equipment and BMS is as below.

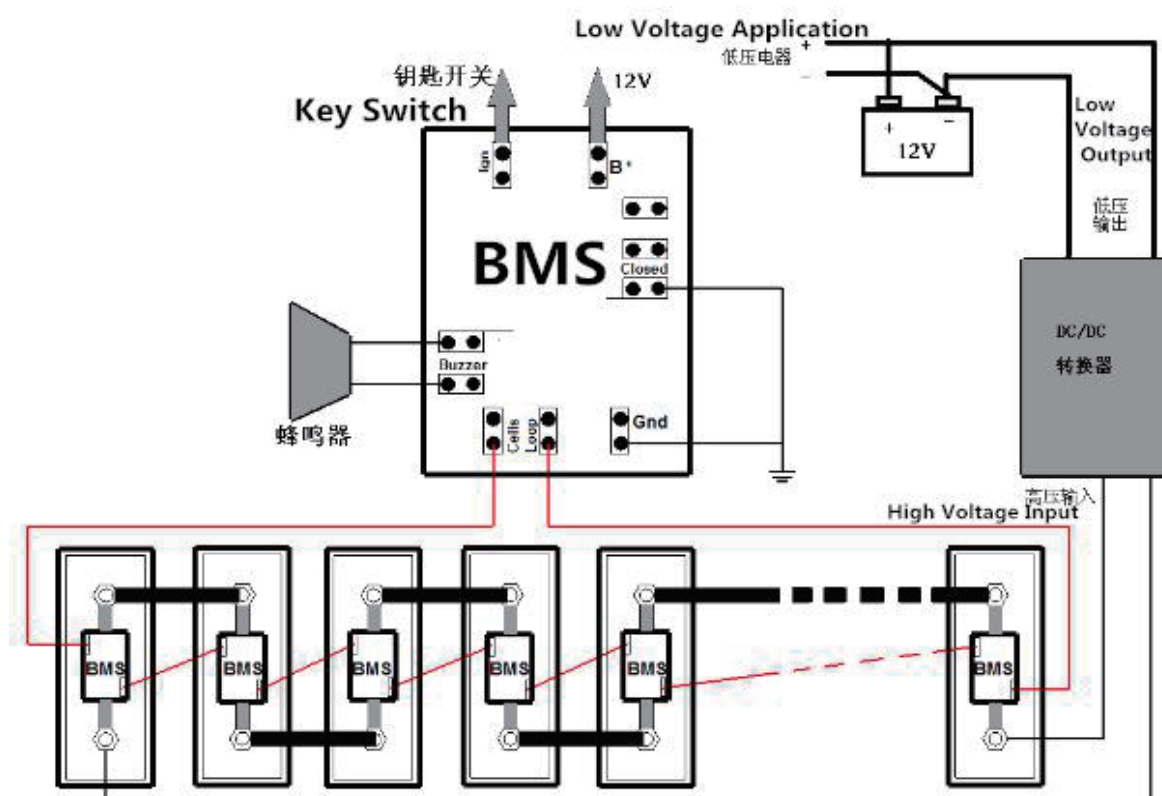

2. Basic Function

- 2.1 Converter high voltage from power battery to low voltage of 12Vdc.
- 2.2 Management charging process of 12v auxiliary battery.
- 2.3 Integrated with HVIL function. (High Voltage Internal Lock).
- 2.4 Compliant with CAN 2.0 regulation, display working status, fault code, etc.
- 2.5 Via CAN BUS, functions, OBD diagnosis, working status display, modifying working

parameters, encoding, etc, are achievable.

2.6 Protection function including reverse protection, input lower voltage and over voltage protection, output over voltage , output over current, output short circuit protection, over heating protection etc,.

2.7 Input terminal pre-charge function.

2.8 Fully sealed waterproof structure, natural air cooling.

3. Technical Specification

3.1 Product name

3.1.1 Model Name

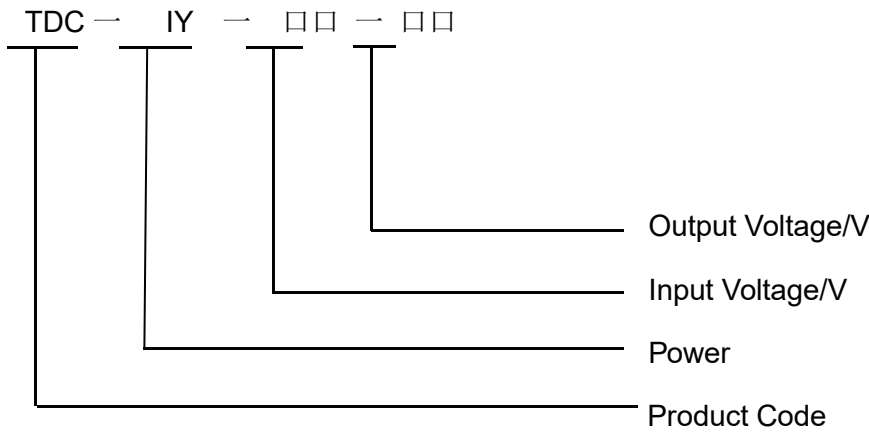

3.1.2 Model name method

Item	Description
Power	I=1000W , IY+1000W, J=1500W , JH=1500W, K=2000W, L=2500W, M=3000W

3.1.3 Configuration

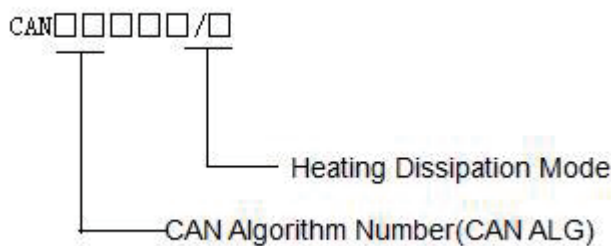

3.1.4 Configuration No. Name Way

Item	Description
CAN Algorithm Number(CAN ALG)	5000-9999, e.g: CAN ALG 5100: with 12V Enable.
Cooling	F--With Fan , Forced Air Cooling. N--Natural Air Cooling , W--Water Cooling

3.1.5 Label Definition.



3.2 Model List

Nominal Input	Nominal Output	Model	Configuration	Heating Dissipation Mode
72V	14.0V	TDC-IY-72-12	CANxxxx/N	Natural Air Cooling
96V/108	14.0V	TDC-IY-108-12	CANxxxx/N	Natural Air Cooling
144V	14.0V	TDC-IY-144-12	CANxxxx/N	Natural Air Cooling
320V	14.0V	TDC-IY-320-12	CANxxxx/N	Natural Air Cooling

3.3 Features

Model		TDC-IY-72-12	TDC-IY-108-12	TDC-IY-144-12	TDC-IY-320-12
Input	Nominal Voltage	DC72V	DC96V/DC108V	DC144V	DC320V
	Nominal Current	15A	10A/11A	5A	3.5A
	Max Working Current	≤25A	≤18A	≤12A	≤8A
	The range of input voltage	44-97V	72-162V	100-200V	220-450V
	The protection of under voltage	42V±2V	70V±2V	96V±4V	215V±5V
	The protection of over voltage	100±3V	162±4V	215±5V	455±5V
	Activation Time	≈0.5S @ VIN=72V	≈0.5S @ VIN=108V	≈0.5S @ VIN=144V	≈0.5S @ VIN=320V
Output	Nominal Voltage	14.0V±1%			
	Voltage Range	8.0-15V			
	Nominal Output Current	72A			
	Nominal Output DC Power	1000W			
	Peak Power	1200W Continues 6 Minutes			
	Max Efficiency	≥94%			
	Instant Responding	≤50ms			
	The Adjustment rate of voltage	1%			

	The Adjustment rate of loading	$\leq 1\%$
	The steady voltage accuracy	$\leq 1\%$
	The steady current accuracy	$\leq 2\%$
	The leaking current of output terminal	$\leq 1\text{mA}$
	The current leakage	$\leq 1\text{mA}$
	The Output Ripple	$\leq 276\text{mV @ } 12\text{V}$
Signal	12Enable Signal	6-30V
	12V Enable current	$\leq 1\text{mA}$
Safety Regulation and Other	Hi pot Test	Input to earth: 2000VAC<10ma 1 min.
	Grounding Resistance	The value of the resistor between grounding and heating sink is smaller than 100 ohm.. The testing current is 25A AC.
	Voltage Resistance	2000V Between Input terminal and shell, there is no Corona,ionization,Flying Fox,Breakdown phenomenon.
	Insulation Resistance	In ambient temperature (23±2) °C and humidity 80%~90%, input to shell is not smaller than 20MΩ, testing voltage is 1000VDC.
	Noisy	$\leq 50\text{dB @ } 1\text{m away from converter}$
	Electromagnetic Immunity	Compliant with GB/T 18487.3-2001 11.3.1

Electromagnetic Abusive	Compliant with GB/T 18487.3-2001 11.3.2
Harmonic Current	Compliant with GB 17625.1-2003 6.7.1.
Activation Inrush Current	≤3A
Current Raise Time	100% to 10% ≤50mS; 100% to 0% ≤200mS
Protection Grade	IP67
Anti-Vibration	10-25Hz, Amplitude 1.2mm, 25-500Hz 30m/s ² , 8 h each direction
Reliability	MTBF 150000 H
Ambient Humidity	5%~95% NO condensation
Ambient Temp.	-40 ~ 65℃
Storage Temp.	-55℃ ~ +85℃

3.4 Efficiency Curve

3.4.1 108V TO 12V Efficiency Curve

Input voltage 115V, nominal output voltage, the efficiency value tested result under 10 different current.

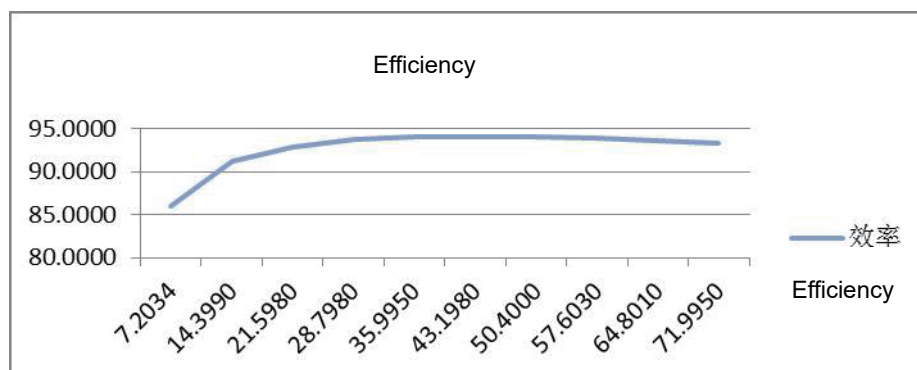

Nominal output power, the input voltage changing between min value and max value, the efficiency value tested under 10 different voltage.

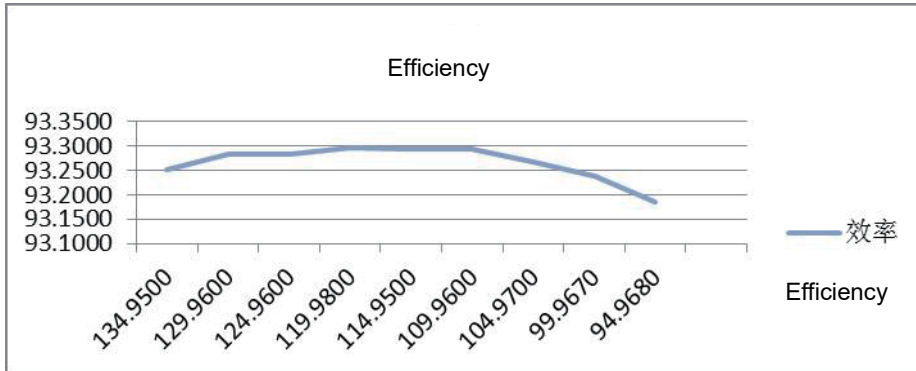

3.4.2 144V TO 12V Efficiency Curve

Input voltage 144V, nominal output voltage, the efficiency value tested result under 10 different current.

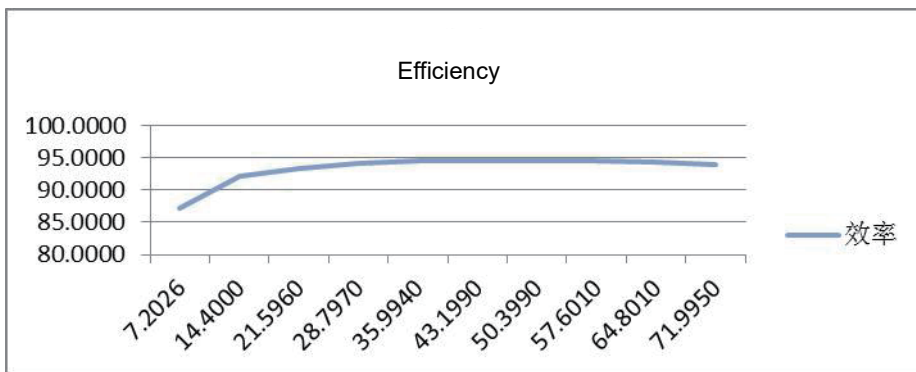

Nominal output power, the input voltage changing between min value and max value, the efficiency value tested under 10 different voltage.

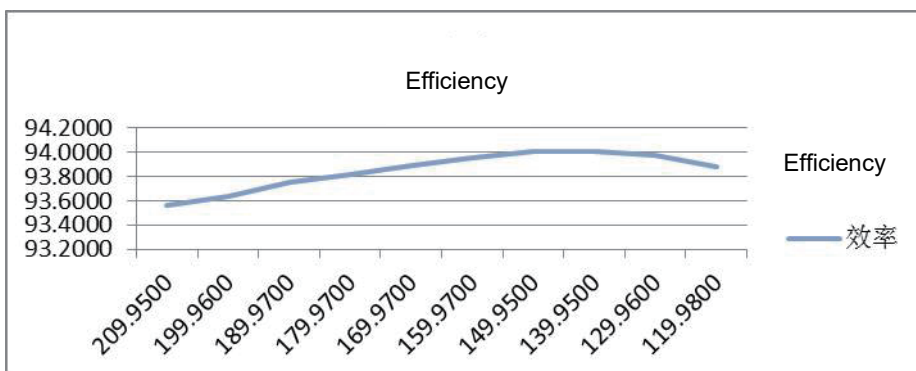

3.5 108V to 12V temperature drop curve.

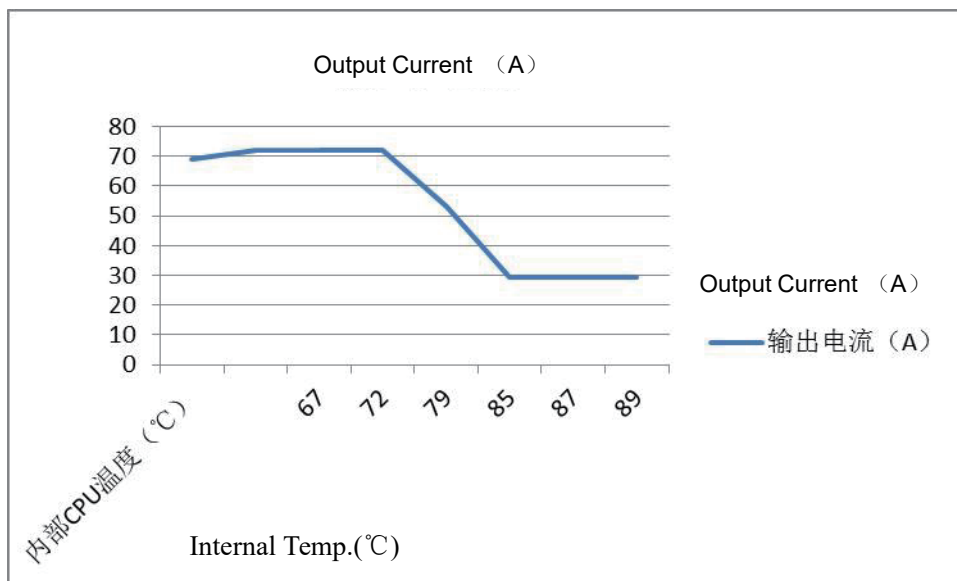

3.6 Withstand (Hi pot) Performance.

The dielectric strength between crimping to grounding and non-electric connected circuit, shall be bear the withstand testing as below table. The testing voltage is AC voltage. There should be no Corona,ionization, spark-over, ,Breakdown phenomenon.

Table 1

Items	Testing Voltage	Testing time	Current Leakage value
Input +&- to shell	2800V DC	1min	≤0.1mA
Output +&- to shell	2000V AC	1min	≤10mA

3.7 Isolation Performance

The dielectric strength between crimping to grounding and non-electric connected circuit, shall be bear the withstand testing as below table. The testing voltage is AC voltage. There should be no Corona,ionization, spark-over, ,Breakdown phenomenon.

Table 2

Items	Testing Voltage	Testing time	Testing value
Input +&- to shell	1000V DC	1min	≥20M

4. Protection Function

The Protection of under input voltage	Shut off in 60s once Input voltage lower than protection value . Resume automatically in 120s after the fault is removed.
The Protection of over input voltage	Shut off once over input voltage is overt than the protection value; Resume automatically as long as default is removed.
The reversion protection of input connection	No damage, no working. Resume to work with normal wiring.
The short circuit protection of Output	When the output voltage is lower than 6V, output current descend to 1/4 of nominal current. .Resume automatically when the short circuit is removed , output voltage increased to above 6V.
Over temperature protection	Output power start to derating once shell temperature is over 85 deg. Shut off at 90 deg.
HVIL	Shut off if the input plug is unfasten or loose.
Communication Protection	The CAN communication invalid time is over 5s, converter shut off.

5. Interface Definition

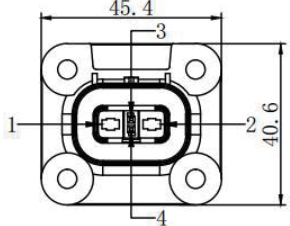
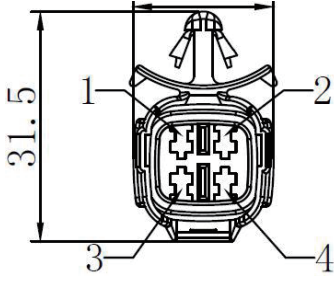
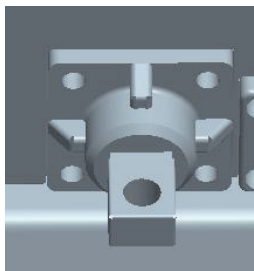
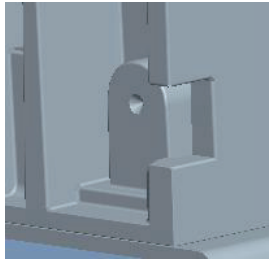
Interface	Terminal Definition	Connector Socket	Connector Plug	Brand	Sectional View
Input Connector	1-DC+; 2-DC-; 3-HVIL 4-HVIL	2103124-4	2103177-4	Tyco	
Signal	1-Enable 2-Failure Signal 3-HVIL 4-HVIL	PP042730 3	/	THB	
DC Output +	M8 Threaded hole	/	/	/	
DC Output -	outer hexagonal flange M8 pole	/	/	/	

6. Signal Interface schematic

6.1 CAN Communication Interface

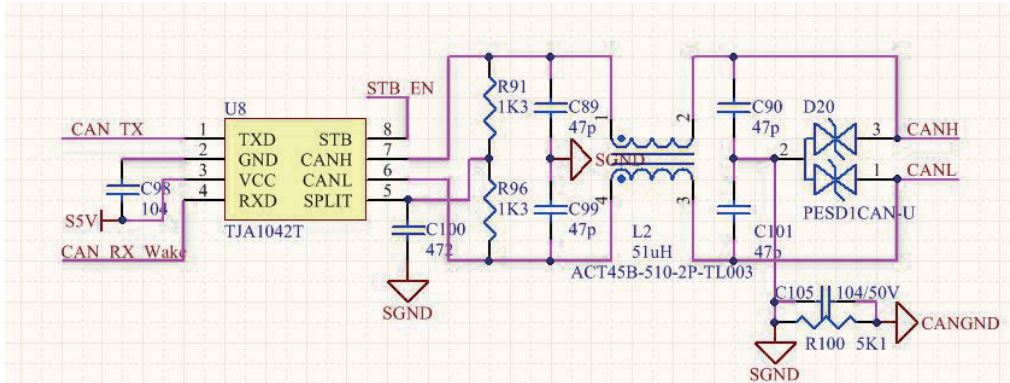

6.2 12V Enable Interface

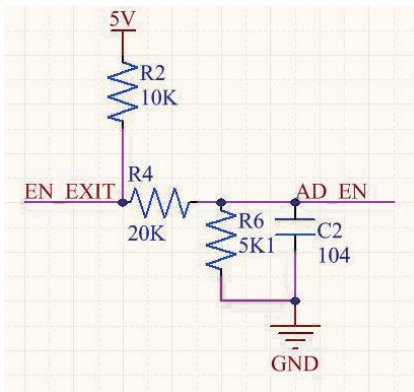

EN_EXIT is the external Enable Signal Input. AD_EN is the detection Signal of SCM.

6.3 Failure Indication/Operating Signal Interface

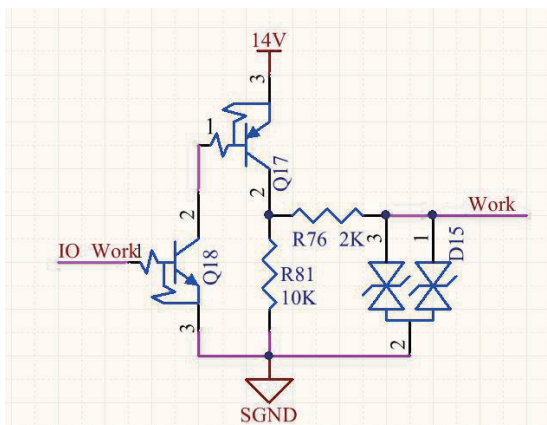

Remark: TO_WORK is the output operating signal of SCM. WORK is the DC/DC output.

7. Schematic Diagram.

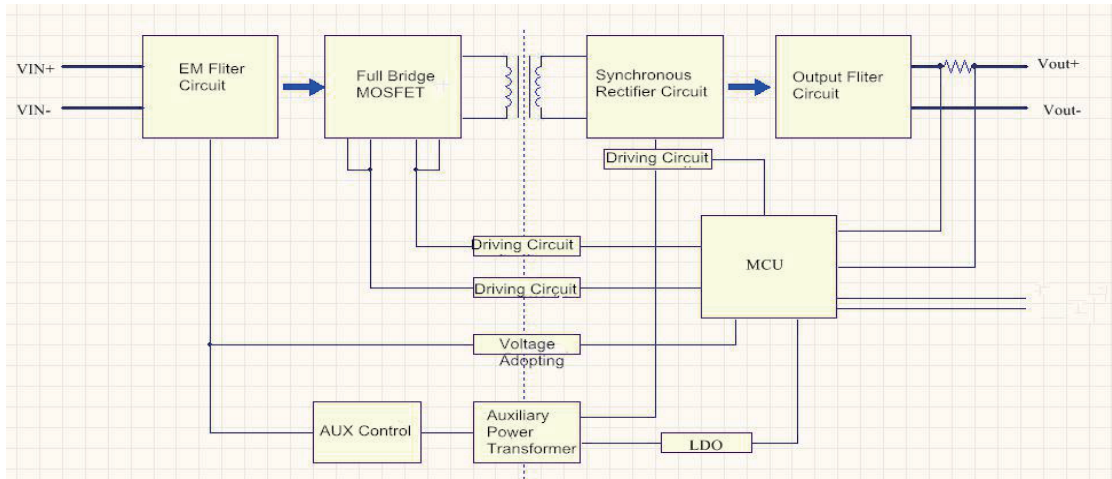

8. The Input Interface Circuit

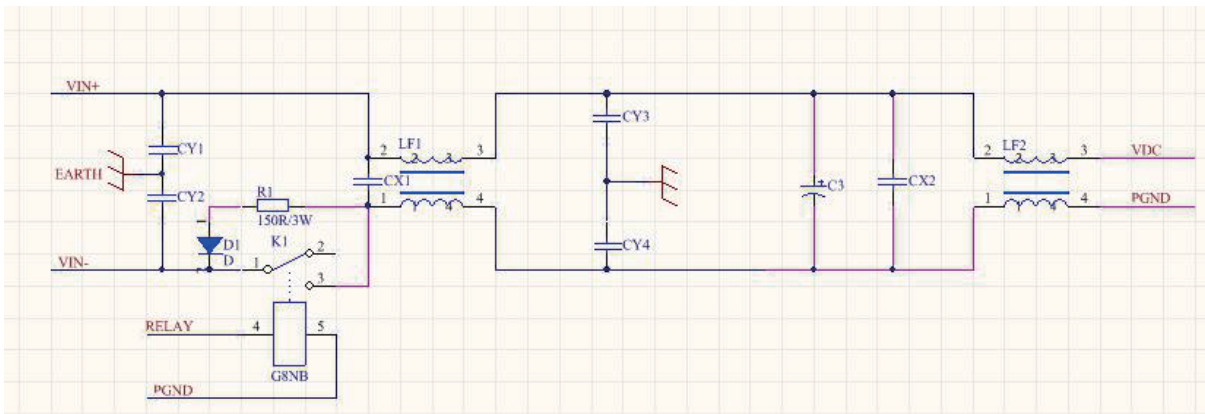

The input interface circuit is composed with pre-charge resistor, anti-reverse diode, relay, EMI Filter and filter capacitor. Refer the below table to capacity of each voltage level and inrush current. Each pre-charge resistor is 150R.

Voltage	72V	96V	144V	216V	320V
Capacity of Capacitor	55UF	55UF	55UF	15UF	15UF
Inrush Current	≤4A	≤4A	≤4A	≤4A	≤4A

9. The Output Interface Circuit

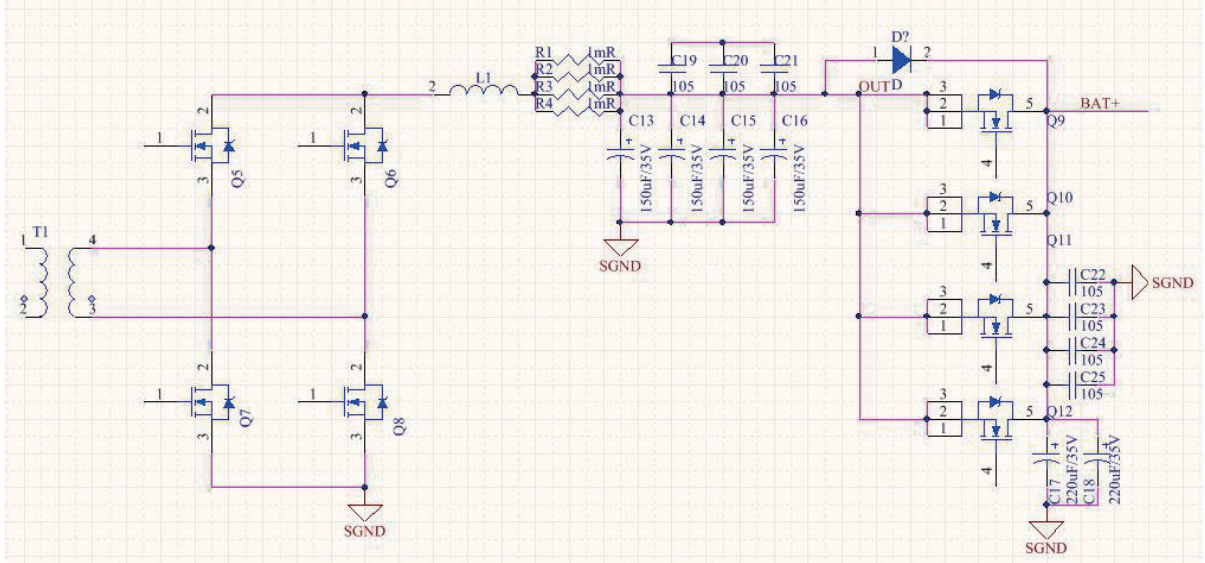

The input interface is composed with Anti-backflow circuit, filter capacitor, synchronous rectifier circuit and LC filter. The capacity of the capacitor is 440UF.

10. Power Destiny.

	Net Weight	Volume	Unitary Mass Density	Volume Density
Unit	kg	L	kw/kg	kw/L
Value	2.5	2.2	0.4	0.45

11. The Installation Dimension.

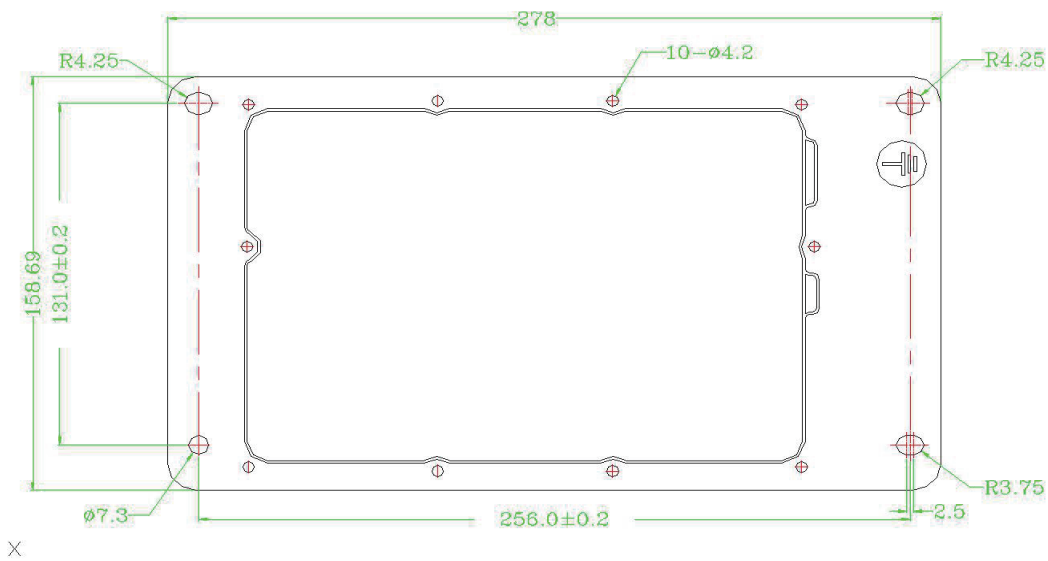
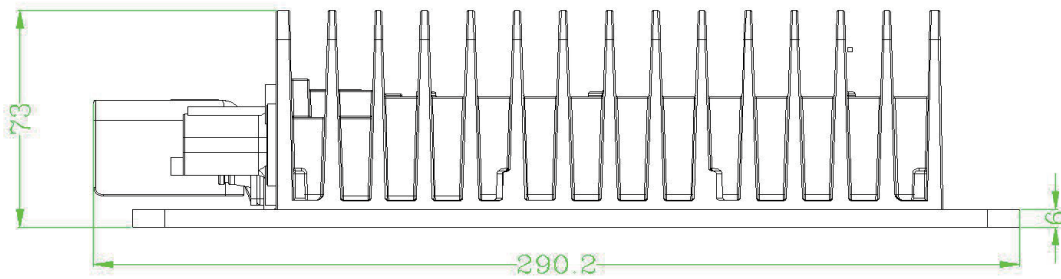
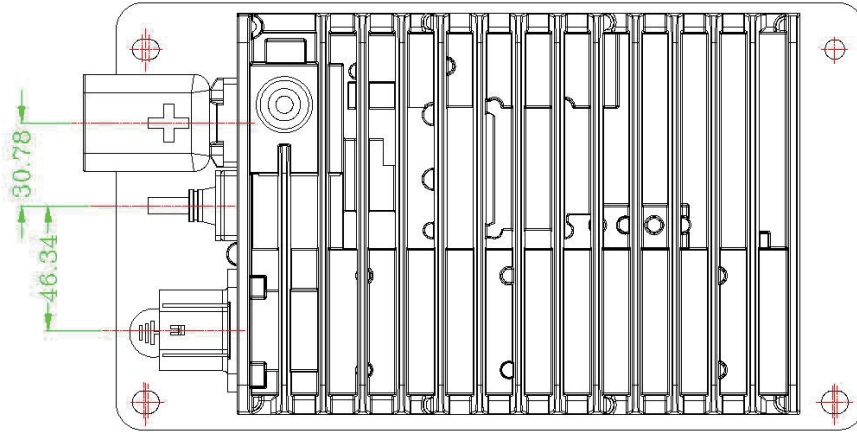

X

12. Installation Diagram.

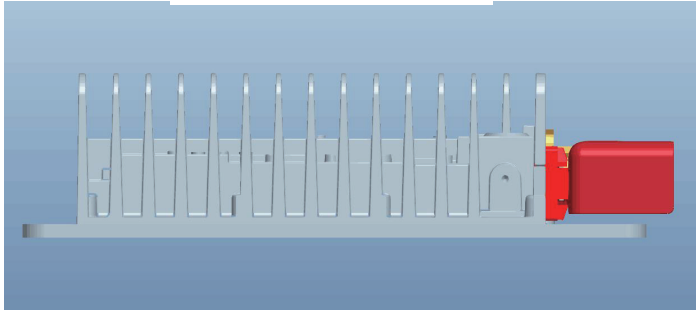
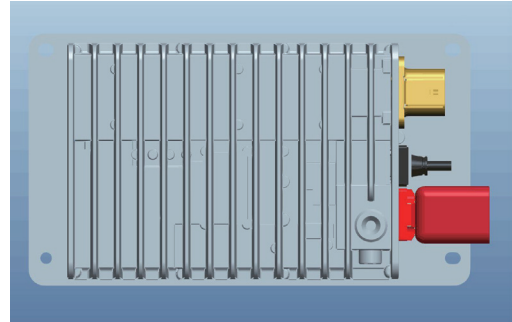
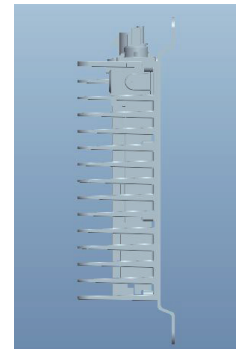
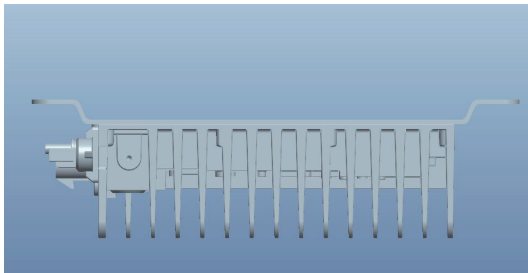
2. Best**1. ok****3. Prohibited****4. Prohibited**

13. Application Requirements

13.1 The HV DC fuse F1 should be installed in the PDU(Power Distribution Unit) for DC-DC input terminal. The fuse's maximum current should be 1.5-2 times than the maximum input current. The fuse of 10A 960v is suggested to TDC-IY-320-12. The fuse of 20-25A 250V is suggested to TDC-IY-144-12. The fuse of 36-50A 250V is suggested to TDC-IY-72-12.

13.2 A fuse blade is required to connect in series with DC-DC output terminal, connecting with polarity of auxiliary battery pack. Then chassis is connected to the negative pole. See below diagram. The fuse blade is decided on maximum current. Normal is above 100A.

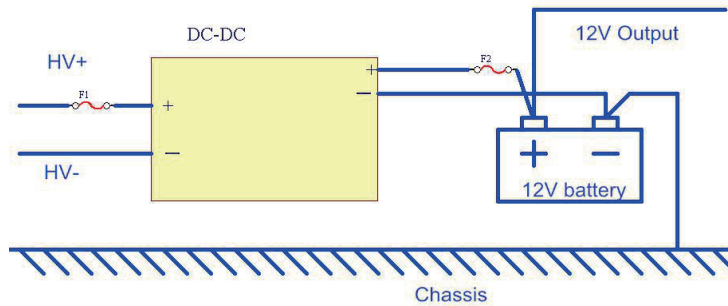

13.3 The terminals of battery pack need to be reliable, no loose. Otherwise, it may cause the damage to DC/DC converter.

14. Installation Requirements

1. The heating sink should be facing up. Reversion is prohibited. More than 10cm distance is required between heating sink and obstruction.
2. The output positive pole is M8 threaded hole, applying 14mm outer hexagonal nut. The tightening force is 14-16N.m.
3. The output negative pole is outer hexagonal flange M8 pole. The tightening force is 14-16N.m.